

©Kawasaki Motors Corp 1974 Printed in USA



*obsolete*

**PROBLEM:**

Oil leakage from the front forks was an occasional problem on the H1 and H2.

**SOLUTION:**

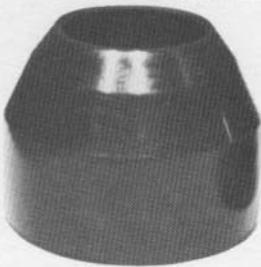
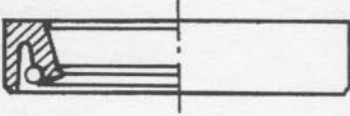
A new fork dust shield and new oil seal have been developed to insure against oil leakage and excessive wear from dirt entering the slider.

	OLD	NEW	
DUST SHIELD	 OLD P/N 44010-018	 NEW P/N 44010-021	Dust shield Quantity required: 2
OIL SEAL	 OLD P/N 44009-012	 NEW P/N 44009-014	Oil Seal Quantity required: 2
I.D. MARK	RSD	TB4	

**PARTS INFORMATION:**

DESCRIPTION	OLD PARTS		NEW PARTS		INTER-CHANGE OLD ↔ NEW	EFFECTIVE I.D.
	OLD P/N	REMARKS	NEW P/N	REMARKS		
Dust Shield	44010-018	Single Taper	44010-021	Double Taper	← ⊙ →	KAF-62467
Oil Seal	44009-012	"RSD"	44009-014	"TB4"	← ⊠ → ← ⊙ →	H2F-19037

⊙ = interchangeable    X = not interchangeable    ⊠ = not available

**CAUTION:** Do not attempt to re-use old oil seals, since they are most often damaged during removal. Always use the new style seals for replacement.

**WARRANTY INFORMATION:**

This is a factory production change for routine product improvement. This bulletin is for notification of modification only, not for warranty authorization. ■