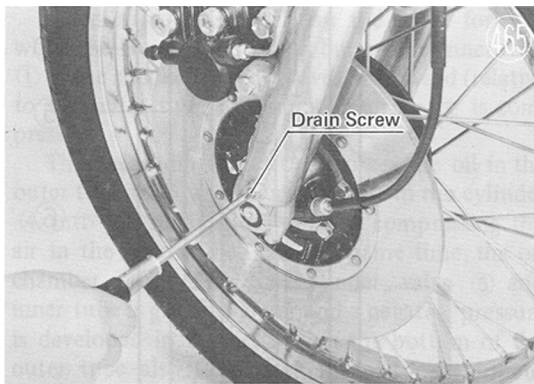

Table 43 Fork oil

	Type	Amount per side	Oil level from top of tube
H1	SAE 10W	5.7 oz (170 cc)	15.2 in (385 mm)
KH500	SAE 10W	5.9 oz (175 cc)	16.2 in (412 mm)
H2	SAE 10W	5.9 oz (175 cc)	14.9 in (379 mm)

Every 6,000 miles (10,000 km), or less if the oil appears dirty, the front fork oil should be changed. To drain out the old oil, first remove the drain screw from the lower end of the outer tube on each side. Stand the motorcycle on both wheels and push down on the handlebars a few times to pump out the oil. Replace the drain screws, remove the top bolt from each side, and pour in the specified type and amount of oil.



e. Inner tube damage

Visually inspect the inner tube and repair any damage, or replace the tube if the damage is not repairable. Since inner tube damage will also damage the oil seal, replace the seal, too.

3. ELECTRICAL SYSTEM

1) Ignition Circuit (H1-E)

The main components of the AC generator are the starter, rotor, SG (signal generator) rotor, pickup, yoke plate, and carbon brushes (neutral brushes and personal brushes). On the front of the rotor there are two concentric slip rings, an outer ring and an inner ring, that are in constant contact with the carbon brushes. Two slits break the inner ring into two parts which have no electrical continuity between them. One half of the broken inner ring is connected by three ribs to the outer ring, so there is electrical continuity between the outer ring and that half of the inner ring. Two neutral brushes ride around the outer ring, and three personal brushes ride on the inner ring.

The AC generator has six sets of starter coils. Five of these are connected in series-parallel for battery charging, and the sixth winding is mounted on the inner part of the starter and is used alone for the ignition system. A yoke plate is fixed to

the starter, and on the plate are mounted pickups (N and S), the two neutral brushes, and the three personal brushes.

AC generator Rotor

466

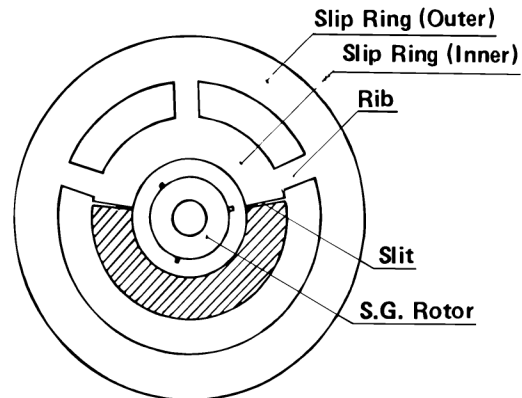

When the engine is kicked over, the AC generator rotor on the end of the crankshaft rotates and a current is generated in the ignition winding of the generator. This generated current flows to Unit A, where it is rectified by a diode and charges up a capacitor. When the generator rotor turns, the SG rotor on the end of the shaft also rotates, and a small amount of current is generated in the pickup coil at the moment when the SG rotor projection passes the pickup projection. This current goes to Unit A to the thyristor gate lead, and causes the thyristor to start conducting (i.e., it turns it on). At the moment the thyristor is turned on, one of the three personal brushes (for the right, left, or center cylinder) is always positioned on the conducting portion of the inner slip ring, and this brush and the thyristor together complete the path for discharging the capacitor. The capacitor's current goes first through the primary winding of the ignition coil corresponding to the personal brush aligned on the inner ring, then next through the personal brush to the inner ring, through the three ribs to the outer ring, from the outer ring through the neutral brush to ground, up through the thyristor, and finally back to the other side of the capacitor. The sudden current flow through the ignition coil, in combination with the high turns ratio of the coil windings, and the spark plug gap, make the original 300 volts from the capacitor into a 30,000-volt spark across the spark plug electrodes.

The mechanism that distributes the current to the correct ignition coil is called a distributor, but in the AC generator the rotor is doing the work of a distributor. So actually, the "distributor" in this case consists of the AC generator rotor, the neutral brushes, and the personal brushes. Since this distributor operates with the relatively low voltage of the primary side of the ignition coils, it is also referred to as a low-voltage distributor.